

# Product datasheet

Dock shelter

ASSA ABLOY DS6060P

**ASSA ABLOY**

ASSA ABLOY Entrance Systems

The global leader in  
door opening solutions



# Copyright and Disclaimer Notice

Although the contents of this publication have been compiled with the greatest possible care, ASSA ABLOY Entrance Systems cannot accept liability for any damage that might arise from errors or omissions in this publication. We also reserve the right to make appropriate technical modifications/replacements without prior notice.

No rights can be derived from the contents of this document.

Color guides: Color differences may occur due to different printing and publication methods.

No part of this publication may be copied or published by means of scanning, printing, photocopying, microfilm or any other process whatsoever without prior permission in writing by ASSA ABLOY Entrance Systems.

Copyright © ASSA ABLOY Entrance Systems AB 2006-2017.

All rights reserved.

ASSA ABLOY, Besam, Crawford, Albany and Megadoor as words and logo are trademarks belonging to the ASSA ABLOY Group

# Technical facts

## Features

Sizes – nominal height	3200, 3400, 3600, 3800, 4000, 4200, 4400, 4600 mm
Sizes – nominal width	3200, 3250, 3400, 3450, 3500 mm
Sizes – top curtain	1000, 1200, 1500 mm
Sizes – side curtain	600, 700 mm
Sizes - nominal depth	600 mm, 900 mm
Curtain colour	Black
Parking guides	White
Wall fixings	Concrete, sandwich, light concrete, loadhouse, cavity, insulated panel

## Performance

Top and side curtain material:	double layer high quality polyester coating on both sides
Front and rear frame	extruded aluminium profiles

### Top and side curtains

Double layer high quality polyester:	
Thickness:	3.0 mm
Coating:	Front and back
Weight:	Approx. 3400g/m <sup>2</sup>
Flammability:	DIN 75200
Tensile strength:	DIN 53354 <ul style="list-style-type: none"><li>• Longitudal: 7000N/5cm</li><li>• Transverse: 5000N/5cm</li></ul>
Tear elongation:	DIN 53363 <ul style="list-style-type: none"><li>• Longitudal: 750 N</li><li>• Transverse: 900 N</li></ul>

One layer high quality polyester:	
Thickness:	0.5 mm
Coating:	Front and back
Total weight:	Approx. 680 g/m <sup>2</sup>
Flammability:	DIN 75200
Tensile strength:	DIN 53354 <ul style="list-style-type: none"><li>• Longitudal: 2700N/5cm</li><li>• Transverse: 2300N/5cm</li></ul>
Tear elongation:	DIN 53363 <ul style="list-style-type: none"><li>• Longitudal: 300 N</li><li>• Transverse: 250 N</li></ul>

# Contents

Copyright and Disclaimer Notice .....	2
Technical facts .....	3
Contents .....	4
1. Description .....	5
1.1 Application .....	5
1.2 Mode of operation .....	5
1.3 Overview .....	5
1.4 Standard .....	5
1.5 Options .....	5
1.6 Description of available options .....	6
2. Selection Guide .....	7
2.1 Installation height .....	7
2.2 Top curtain length .....	7
2.3 Free space above .....	7
2.4 Nominal depth .....	7
2.5 Example .....	7
3. Specifications .....	8
3.1 Dimensions .....	8
3.2 Nominal width selection guide .....	9
4. Construction .....	10
5. Building and space requirements .....	11
5.1 Fixing points .....	11
5.1.1 Fixing points dimensions .....	12
5.2 Wall fixings .....	13
5.2.1 Cavity wall .....	13
5.2.2 Concrete wall .....	13
5.2.3 Insulated wall .....	13
6. Service .....	14
Index .....	15

# 1. Description

## 1.1 Application

The ASSA ABLOY DS6060P curtain dock shelter parallel is the standard solution for energy saving oriented operators. The vehicle reverses into the dock shelter which seals it off with flexible side and top curtains, giving weather protection during the loading and unloading process. The result is an improved working environment and goods protection. The curtain material has a very high wear and tear resistance. The ASSA ABLOY curtain dock shelter programme comprises a number of models, meeting all customer demands and suitable for a wide range of vehicle sizes.

## 1.2 Mode of operation

The ASSA ABLOY DS6060P curtain dock shelter parallel comprises a front and rear extruded aluminium section frame connected by parallel bracing arms. Should the vehicle be parked inaccurately, both sides of the shelter will spring back automatically reducing damage to both the vehicle and the dock shelter to the bare minimum. The self-adjusting roof frame rises automatically independent of the side frames, in case of very high vehicles.

This construction also allows the dock shelter to be installed a short distance above external ground level. The ASSA ABLOY DS6060P curtain dock shelter parallel is available in a wide range of dimensions to meet the customer's individual demand.

## 1.3 Overview

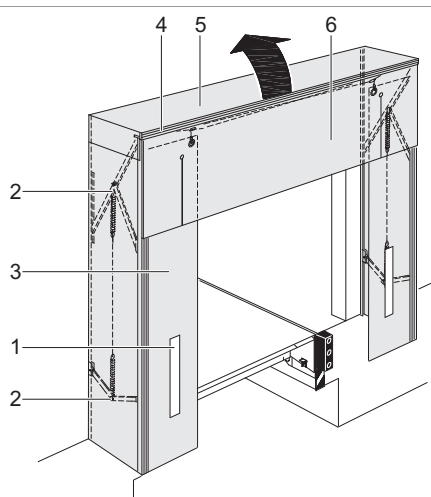

- 1) White parking guides
- 2) Bracing arms
- 3) Side curtains
- 4) Extruded aluminium section
- 5) Self-adjusting roof frame
- 6) Split top curtain

## 1.4 Standard

Nominal height	3200, 3400, 3600, 3800, 4000, 4200, 4400, 4600 mm
Nominal width	3200, 3250, 3400, 3450, 3500 mm*
Side curtain	600, 700 mm
Top curtain	1000 mm
Nominal depth	600 mm
Curtain color and material	Black PVC fabric
Parking guides	white

\*Consult chapter 3.2 Selection guide

## 1.5 Options

Nominal depth	900 mm
Top part	rain channel
Top curtain	1000 mm splitted 1200 mm standard 1200 mm splitted 1500 mm standard 1500 mm splitted digit on top curtain
Side curtain	reinforced rubber flaps placed left and right in lower corners behind the front curtain. notching on both sides
Parking guides	yellow
Wall fixings	Concrete, sandwich, light concrete, loadhouse, cavity, insulated panel
Corner seals	triangle or round cushions in lower corners of the dock shelter.

## 1.6 Description of available options

Standard options for improved working conditions and less draught into the building.

### A Rain Channel

The unique channel is integrated in the middle of the roof part.

- Controlled water drainage
- The water is led out left and right, not into the loading area

### B Splitted top curtain

4 slits with double overlapping layer of PVC curtain material in the main wear area.

- Flexible coverage of rear top corners of docked vehicle for best sealing

Less draught into the building

### C Digit on top curtain

300 mm high letters or numbers printed in the middle of the top curtain.

Individual customised marking of loading bays

### D Reinforced rubber flaps

Robust rubber flap placed left and right in lower corners behind the front curtain

- Increased pressure on the docked vehicle body for best sealing
- Improved stability for the complete dock shelter in windy area

Less draught into the building

### E Corner seals

Triangle or round cushions covered with PVC curtain material in lower corners of the dock shelter.

Minimization of draught from below during loading and unloading

### F Notching on both sides

From factory a square of the lower corner front curtain is cut out.

- Avoid damaged front curtains due to the collision between vehicle and buffer.

Recommended in combination with min. 140 mm deep buffers, like RB, EBH, EBF or steel spring buffer.

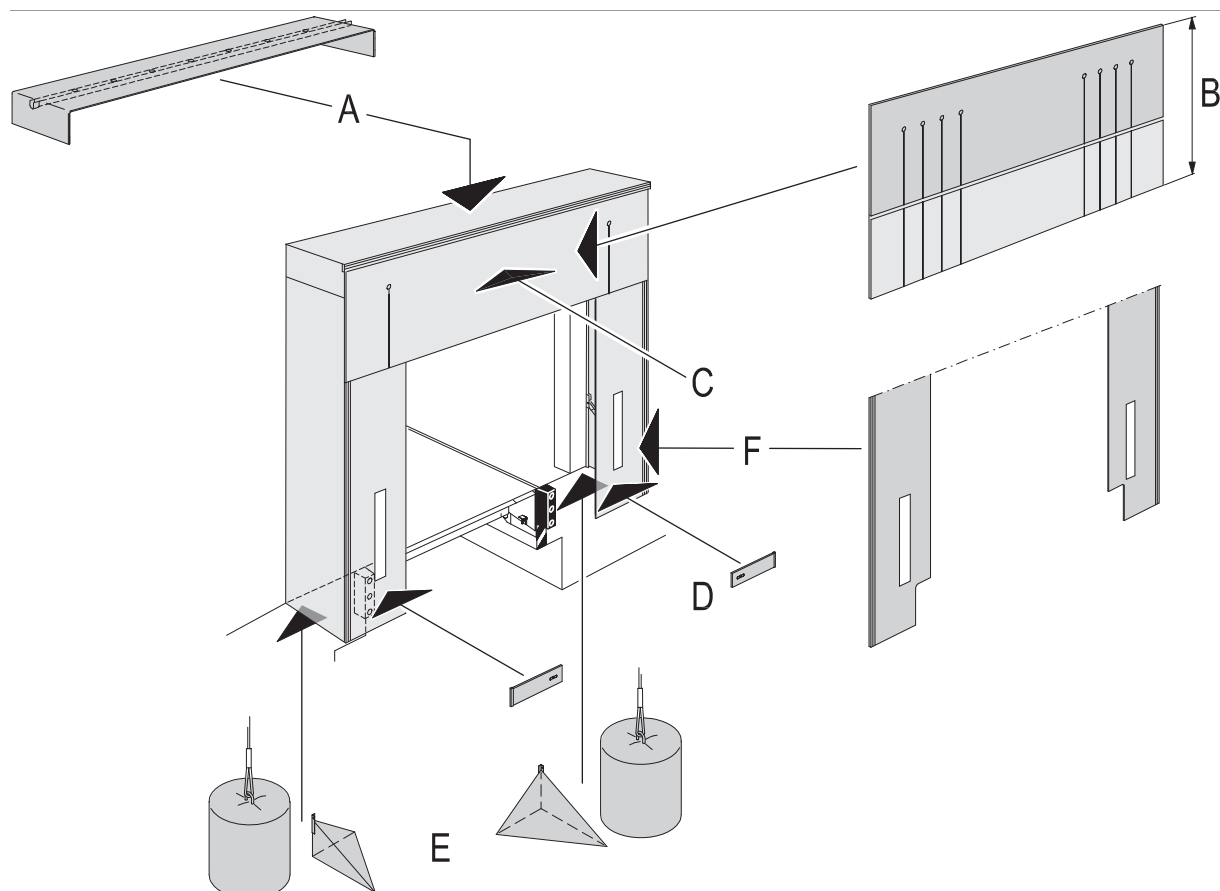

## 2. Selection Guide

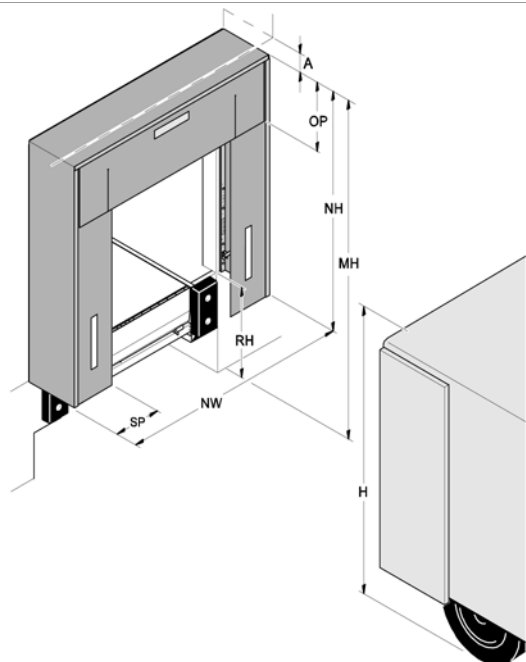

### 2.1 Installation height

The installation height [MH] should be minimum 250 mm above the truck [H] to secure that the pressure is not too big on the complete top part of the shelter and in order to avoid damages or bad functionality.

### 2.2 Top curtain length

The length of the top curtain [OP] should be minimum 200 mm overlapping the truck in order to secure a good sealing effect.

### 2.3 Free space above

The minimum free space above the shelter [A] must not be less than  $NT/2 - 200$ .

### 2.4 Nominal depth

The nominal depth [NT] depends on the slope in front of the building [ $\alpha$ ] and the height of the truck [H]. To make sure that the truck is sealed completely NT should be bigger than  $\alpha * H$ .

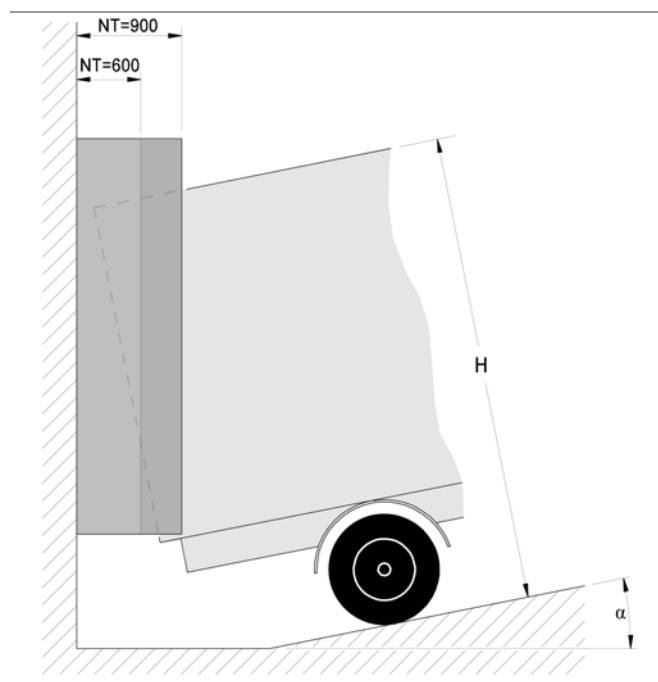

### 2.5 Example

$MH = 4500\text{mm}$   
 $OP = 1000\text{mm}$   
 $H_{\text{max}} = MH - 250\text{mm}$   
 $H_{\text{min}} = MH - OP + 200\text{mm}$   
 $\alpha = 16\% (\sim 9^\circ)$   
 $H_{\text{max}} = 4500\text{mm} - 250\text{mm} = 4250\text{mm}$   
 $NT1 = \alpha * H_{\text{max}} = 0,16 * 4250 = 680 \rightarrow NT 900$   
 $A1_{\text{min}} = 900/2 - 200 = 250\text{mm}$   
 $H_{\text{min}} = 4500\text{mm} - 1000\text{mm} + 200\text{mm} = 3700\text{mm}$   
 $NT2 = \alpha * H_{\text{min}} = 0,16 * 3700 = 592 \rightarrow NT 600$   
 $A2_{\text{min}} = 600/2 - 200 = 100\text{mm}$

## 3. Specifications

### 3.1 Dimensions



Abb.	Dimension	Value (mm)
NB	Nominal width	3200, 3250, 3400, 3450, 3500 mm
NH	Nominal height	3200, 3400, 3600, 3800, 4000, 4200, 4400, 4600 mm
OP	Length of top curtain	1000, 1200, 1500 mm
SP	Width of side curtain	600, 700 mm
MH	Installation height	4500 (recommended)
NT	Nominal depth	600 mm, 900 mm
RH	Ramp height	



### 3.2 Nominal width selection guide

NB	Wall	LH S 3300	LH S 3500	LH M 3300	LH M 3500	LH 3600
3200 mm	□			■		
3250 mm	■	■				
3400 mm	□				■	
3450 mm	■		■			
3500 mm	□					■

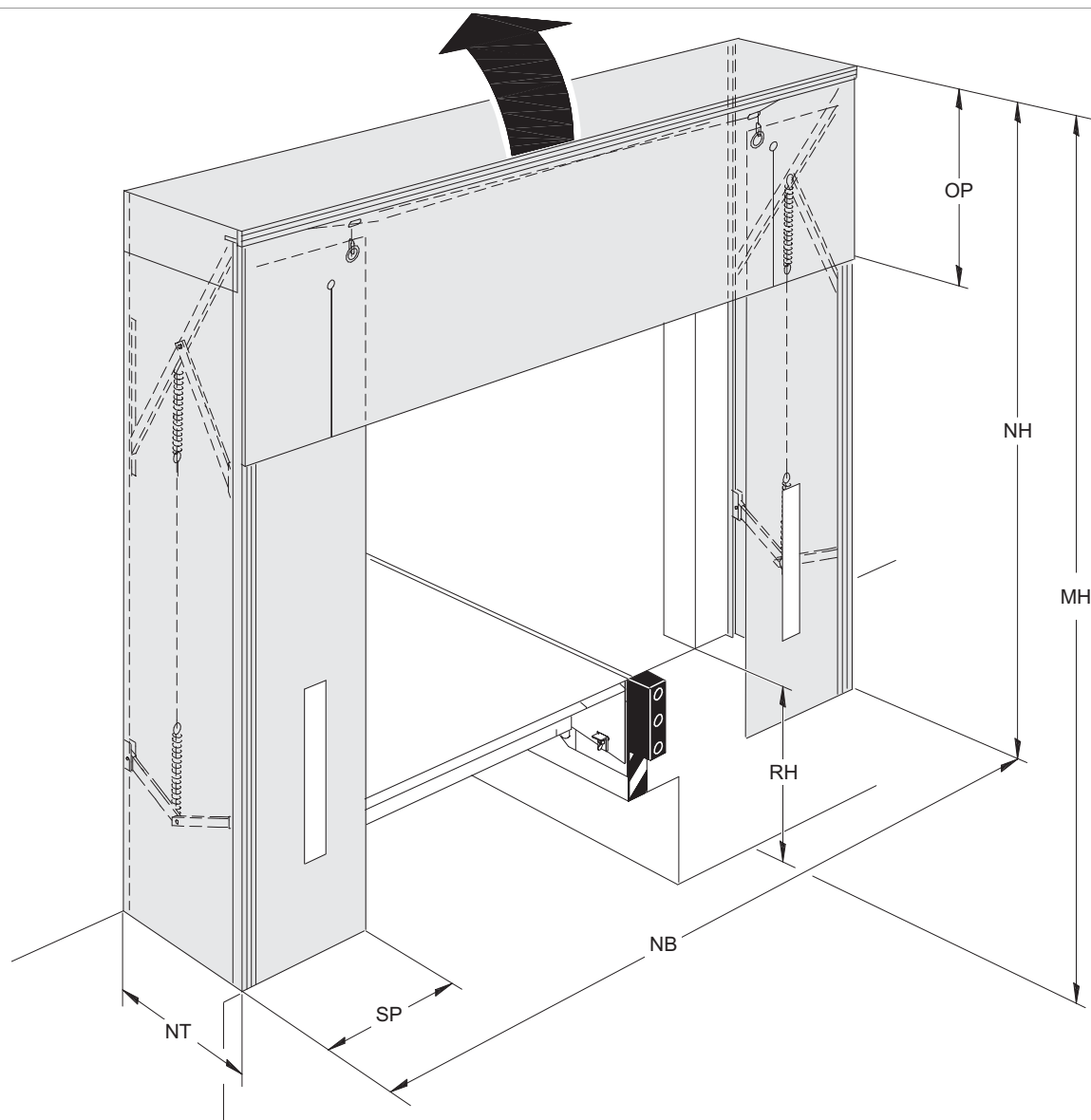
■ = standard

□ = special

LH S = Load house single installation

LH M = Load house multi installation

## 4. Construction

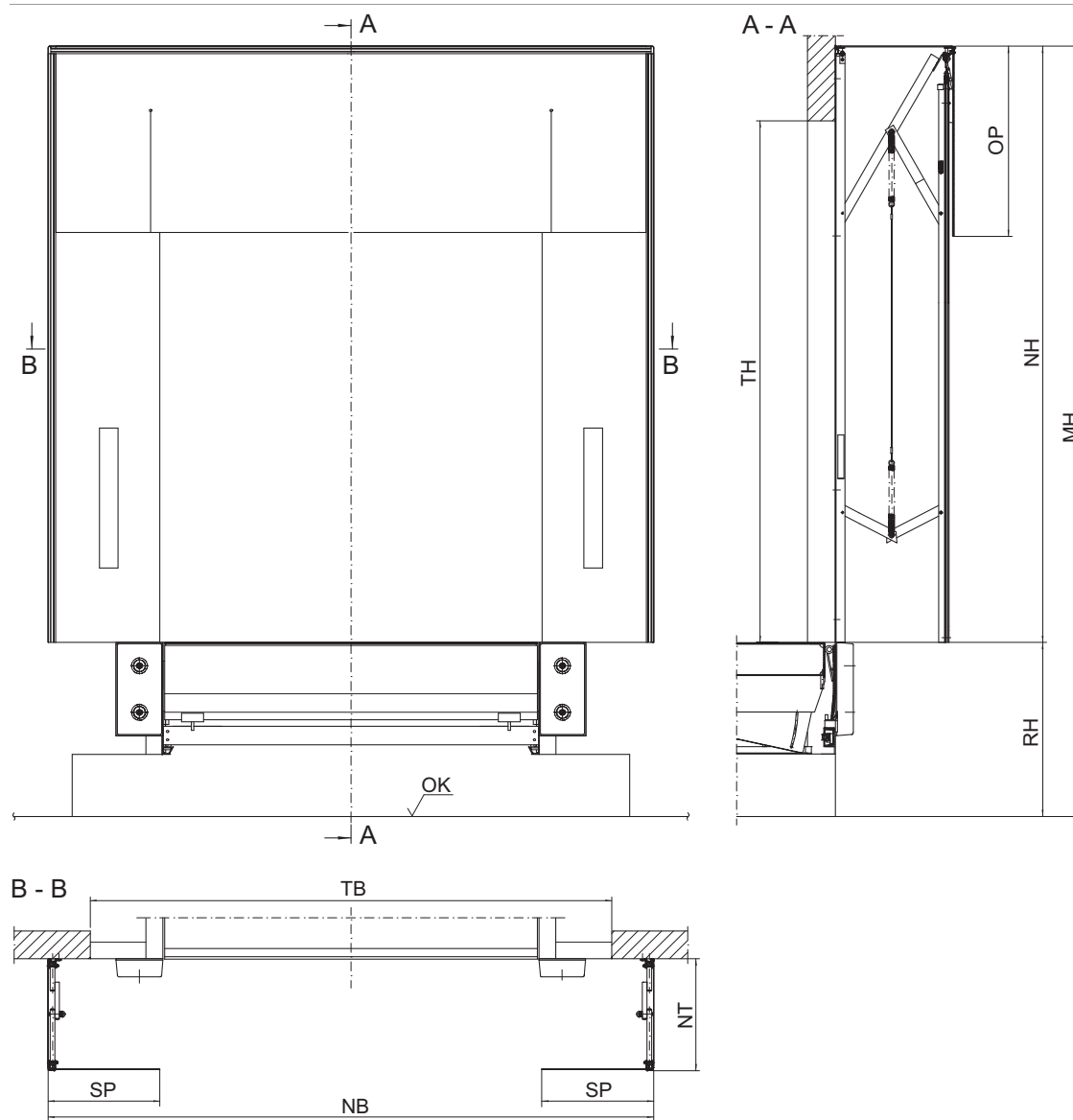

OK	Yard level
DH	Door height
OP	Top curtain
NH	Nominal height
MH	Installation height
RH	Dock height
DW	Door width
SP	Side curtain
NW	Nominal width
NT	Nominal depth

## 5. Building and space requirements

### 5.1 Fixing points

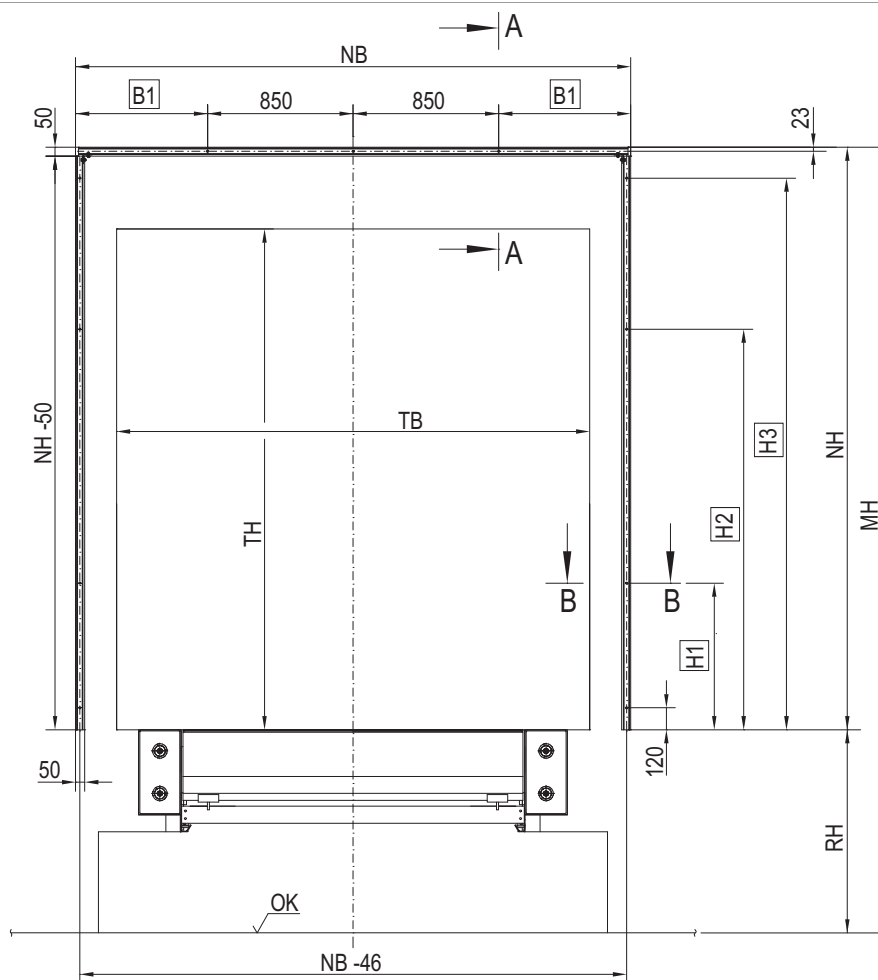

OK	Yard level
DH	Door height
NH	Nominal height
MH	Installation height
RH	Dock height
DW	Door width
NT	Nominal depth
NW	Nominal width

5.1.1 Fixing points dimensions

NB	NH	B1	H1	H2 / NT 600	H2 / NT 900	H3
3200	3200	750	805	2200	1680	3030
	3400	750	805	2400	1880	3230
	3600	750	805	2600	2080	3430
	3800	750	805	2800	2280	3630
	4000	750	805	3000	2480	3830
	4200	750	805	3200	2680	4030
	4400	750	805	3400	2880	4230
	4600	750	805	3600	3080	4430
3250	3200	775	805	2200	1680	3030
	3400	775	805	2400	1880	3230
	3600	775	805	2600	2080	3430
	3800	775	805	2800	2280	3630
	4000	775	805	3000	2480	3830
	4200	775	805	3200	2680	4030
	4400	775	805	3400	2880	4230
	4600	775	805	3600	3080	4430
3400	3200	850	805	2200	1680	3030
	3400	850	805	2400	1880	3230
	3600	850	805	2600	2080	3430
	3800	850	805	2800	2280	3630
	4000	850	805	3000	2480	3830
	4200	850	805	3200	2680	4030
	4400	850	805	3400	2880	4230
	4600	850	805	3600	3080	4430
3450	3200	875	805	2200	1680	3030
	3400	875	805	2400	1880	3230
	3600	875	805	2600	2080	3430
	3800	875	805	2800	2280	3630
	4000	875	805	3000	2480	3830
	4200	875	805	3200	2680	4030
	4400	875	805	3400	2880	4230
	4600	875	805	3600	3080	4430
3500	3200	900	805	2200	1680	3030
	3400	900	805	2400	1880	3230
	3600	900	805	2600	2080	3430
	3800	900	805	2800	2280	3630
	4000	900	805	3000	2480	3830
	4200	900	805	3200	2680	4030
	4400	900	805	3400	2880	4230
	4600	900	805	3600	3080	4430

## 5.2 Wall fixings

### 5.2.1 Cavity wall

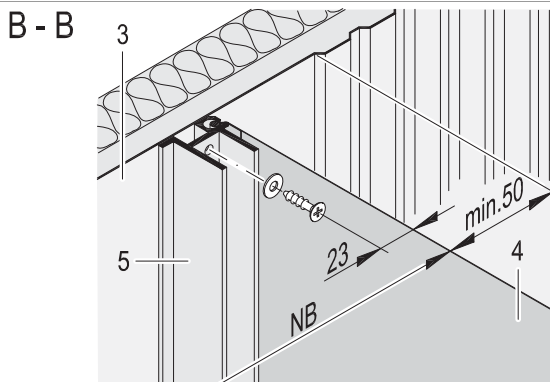
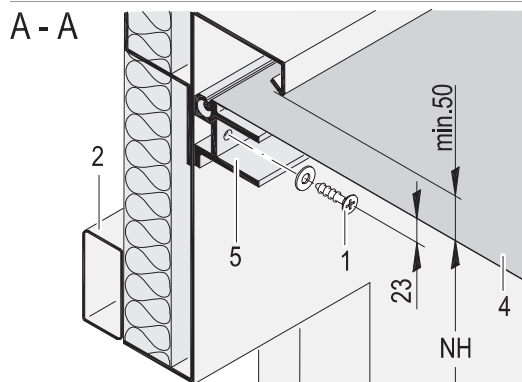

### 5.2.2 Concrete wall

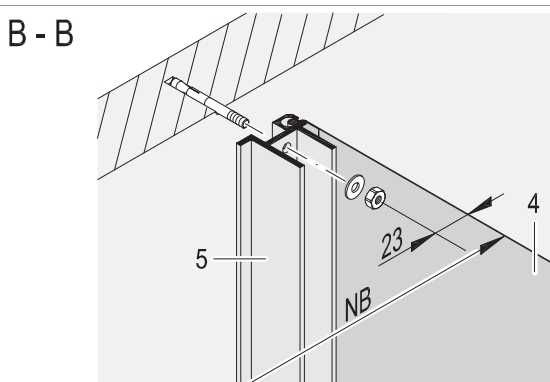
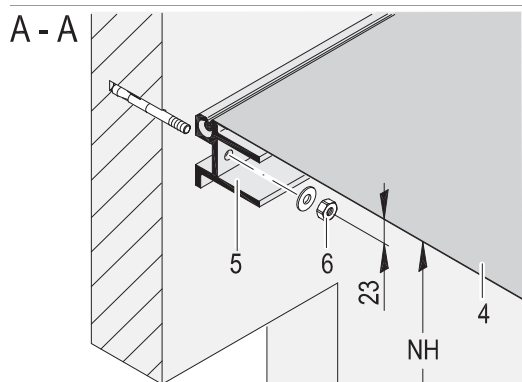

### 5.2.3 Insulated wall

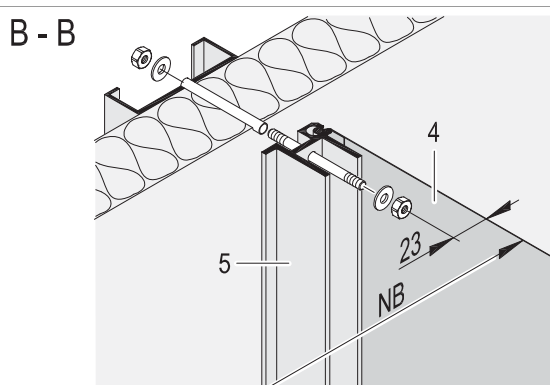
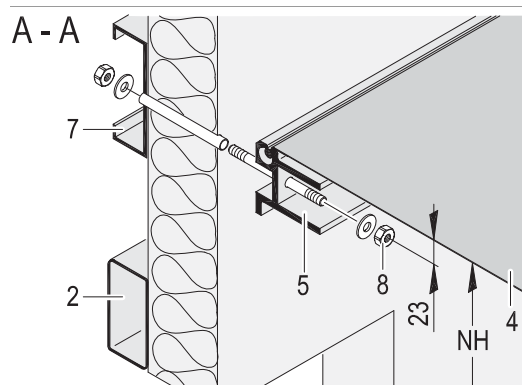

- 1) Self-tapping screw
  - 2) Door mounting frame rectangular tube 80x40x2
  - 3) Sheet metal 3 mm thick
  - 4) Roof cover
  - 5) Extruded aluminium section - rear frame
  - 6) Expansion bolt
  - 7) Mounting frame for dock shelter, 120x40x15x3
  - 8) Threaded bolt with nut, washer and spacer tube
- 2, 3 and 7 are not included in the installation price

# 6. Service

## Preventive Maintenance Program and Modernization Services

As your entrances are part of your business flow, there's every reason to keep them working well. ASSA ABLOY Entrance Systems offers you a maintenance and modernization expertise to rely on. Our Maintenance Programs and Modernization Services are backed by a extensive expertise for all types of industrial door and docking systems, independent of brand. At your disposal is a team of dedicated expert technicians, proven through decades of maintenance, service and satisfied customers.

### Preventive Maintenance Programs

Minimizing lost time, lost energy and unexpected hassle is our team's constant objective. Our service organization can support you 24/7 in maintaining all industrial door and docking systems, independent of brand. If you want to be one step ahead of break-downs, explore our portfolio of Pro-Active Care plans. Naturally, we also offer entrance upgrades to suit your specific wishes and business needs.

### Pro-Active Care - Maintenance plans to fit your business

Regular maintenance can extend the lifetime of your equipment and help prevent unexpected problems. Our technician arrives on-site equipped with the knowledge and tools to service all automatic entrances, independent of brand.

- **Pro-Active Bronze**

The base on which all Pro-Active Plans are built provides the security of knowing that your equipment is regularly inspected and certified for safety, as well as performing optimally. It includes a number of planned on-site visits depending on your needs. Any unplanned service calls required during the term of the contract (including labor, travel and parts) are billed at special Pro-Active Care prices.

- **Pro-Active Silver**

This plan provides all the benefits of Pro-Active Bronze with the added advantage of labor and travel being included for service calls during regular business hours. The only additional charge would be for any parts that may be needed throughout the term of the contract.

- **Pro-Active Gold**

This plan provides the ultimate protection for your automatic entrance investment. It includes all the benefits of Pro-Active Silver, plus replacement of any parts required during an unplanned repair or planned maintenance visit. Pro-Active Gold is an excellent way to budget your automatic door expenses annually.

- **Pro-Active Tailor-Flex**

Our most flexible maintenance and service offering. The Pro-Active Care plan is designed by you, our customer. The plan allows you to balance your maintenance expenses against your real-world budget and presents the option to add or delete a number of maintenance elements to suit your budget goals, while meeting your overall performance and safety needs.

### Modernization

Your entrances are a long-term investment, from which you always want the best. Products develop over time, so do regulations and your business. Let us help you increase energy savings and meet today's standards. We provide advice and modernization kits for outdated installations, ensuring your investment meet requirements and performs optimally for many more years to come.

Re-Active Service		Pro-Active Care				
		Pro-Active Bronze	Pro-Active Silver	Pro-Active Gold	Pro-Active Tailor Flex	
		○	○	○	●	Other customized requests such as Response Time, Performance InfoPack and Advanced User Training
		○	○	●	○	Replacement of worn parts according to preventive Consumable Exchange Program
		○	○	●	○	Replacement of spare parts on breakdowns
		○	●	●	○	Travel and labor for additional call-out visits
		●	●	●	●	Preventive maintenance visits 1-4 times per year
		●	●	●	●	Travel and labor for preventive maintenance visits
		●	●	●	●	Response time and priority on call-outs <24h
		●	●	●	●	Preventive planned maintenance that meets the most demanding standards in the market
	●	●	●	●	●	Safety and quality checks according to applicable regulations and norms. Documentation of test results provided
●	●	●	●	●	●	Documentation of equipment status, assessment and service provided, all generated on site
●	●	●	●	●	●	Highly trained professional technicians with extensive knowledge, state-of-the-art tools and the right spare parts*
●	●	●	●	●	●	Dedicated Professional Customer Care Hotline

● = Included as standard  
 ○ = Available at special prices  
 \* Well-stocked service vehicles with genuine and new spare parts

# Index

## A

Application .....5

## B

Building and space requirements ... 11

## C

Cavity wall ..... 13

Concrete wall ..... 13

Construction ..... 10

Copyright and Disclaimer Notice .....2

## D

Description .....5

Description of available options .....6

Dimensions .....8

## E

Example .....7

## F

Features .....3

Fixing points ..... 11

Fixing points dimensions ..... 12

Free space above .....7

## I

Installation height .....7

Insulated wall ..... 13

## M

Mode of operation .....5

## N

Nominal depth .....7

Nominal width selection guide .....9

## O

Options .....5

Overview .....5

## P

Performance .....3

## S

Selection Guide .....7

Service ..... 14

Specifications .....8

Standard .....5

## T

Technical facts .....3

Top and side curtains .....3

Top curtain length .....7

## W

Wall fixings ..... 13

ASSA ABLOY Entrance Systems is a leading supplier of entrance automation solutions for the efficient flow of goods and people. Building on the long-term success of the Besam, Crawford, Albany and Megadoor brands, we offer our solutions under the ASSA ABLOY brand. Our products and services are dedicated to satisfying end-user needs for safe, secure, convenient and sustainable operations.

ASSA ABLOY Entrance Systems is a division of ASSA ABLOY.

[assaabloyentrance.com](http://assaabloyentrance.com)



ASSA ABLOY Entrance Systems

[assaabloyentrance.com](http://assaabloyentrance.com)